

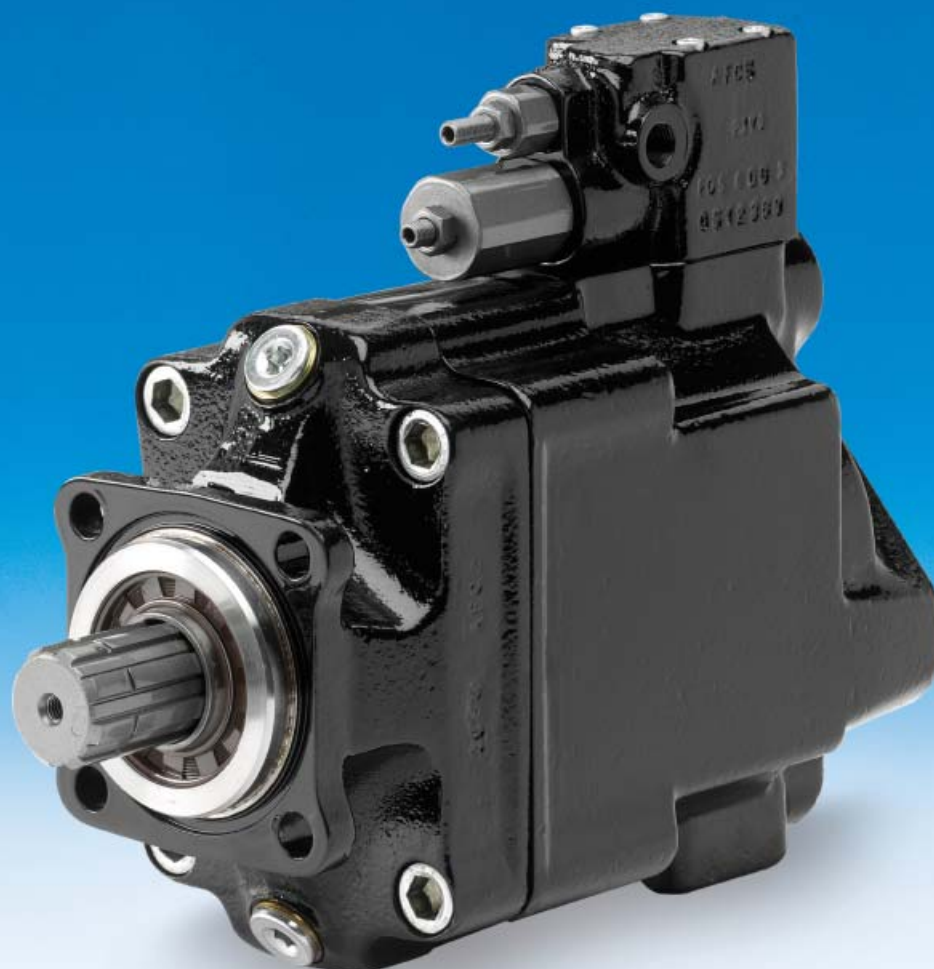

Hydraulic Pump VP1-120

*Variable displacement
Pressure up to 350 bar*

*Catalogue HY17-8221/UK
November 2003*



Contents	Page
General information	3
Specifications	3
Ordering information	3
Standard model numbers	3
VP1-120 cross section	4
Control type LS (for VP1-120)	4
Installation dimensions	5
LS load sensing control function	6
BPV-VP1 unloading valve	6
Suction fittings; start-up	7
Suction fittings for VP1-120	7
Start-up	7

Conversion factors

1 kg	2.20 lb
1 N	0.225 lbf
1 Nm	0.738 lbf ft
1 bar	14.5 psi
1 l	0.264 US gallon
1 cm ³	0.061 cu in
1 mm	0.039 in
1 kW	1.34 hp
$\frac{9}{5} \text{ }^\circ\text{C} + 32$	$^\circ\text{F}$



WARNING

FAILURE OR IMPROPER SELECTION OR IMPROPER USE OF THE PRODUCTS AND/OR SYSTEMS DESCRIBED HEREIN OR RELATED ITEMS CAN CAUSE DEATH, PERSONAL INJURY AND PROPERTY DAMAGE.

This document and other information from Parker Hannifin Corporation, its subsidiaries and authorized distributors provide product and/or system options for further investigation by users having technical expertise. It is important that you analyze all aspects of your application, including consequences of any failure, and review the information concerning the product or system in the current product catalogue. Due to the variety of operating conditions and applications for these products or systems, the user, through its own analysis and testing, is solely responsible for making the final selection of the products and systems and assuring that all performance, safety and warning requirements of the application are met.

The products described herein, including without limitation, product features, specifications, designs, availability and pricing, are subject to change by Parker Hannifin Corporation and its subsidiaries at any time without notice.

Offer of Sale

Please contact your Parker representation for a detailed "Offer of Sale".

The VP1-120 is the world's most powerful variable displacement pump for truck applications. It can be close-coupled to a gearbox PTO (power take-off) or to a coupling independent PTO (e.g. an engine PTO) which meets ISO standard 7653-1985.

An application that makes full use of all the features of the VP1 is truck cranes with a load sensing system. The complex systems of refuse collection vehicles and sewage trucks as well as various combinations of tippers, cranes, snow ploughs, and salt/sand spreaders can also be greatly simplified and optimised with the VP1 pump.

The VP1 provides the hydraulic system with the correct amount of fluid at precisely the right moment, effectively reducing energy consumption and heat generation. This means a smoother and quieter running system with much reduced impact on the environment.

The VP1 is highly efficient, has a small installation envelop and is extremely light. It is reliable, economical and easy to install.

The new frame size, VP1-120, has almost the same installation dimensions as the VP1-45 and VP1-75, and is suitable for all load sensing systems, regardless of make.

Features

- Low energy consumption
- Strong and reliable
- 11 pistons for low noise and smooth running
- Compact and light
- Improved overall economy
- High power-to-weight ratio
- Sturdy design.

Specifications

Frame size	VP1-120
Max displacement [cm ³ /rev]	120
Max pressure [bar]	
- intermittent ¹⁾	350
- continuous ²⁾	300
Response time [ms]	
- max-to-min	20–40
- min-to-max	100–140
Selfpriming speed ³⁾ [rpm]	
2 1/2" suction line, max	1 800
Max input power [kW]	125
Control type	LS
Shaft end spline	DIN 5462
Mounting flange	ISO 7653-1985
Weight (with control) [kg]	26.9

1) Max 6 seconds in any one minute.

2) Refer to page 6: LS control.

3) At an inlet pressure of 1.0 bar (abs.) with mineral oil at a viscosity of 30 mm²/s (cSt).

Ordering information

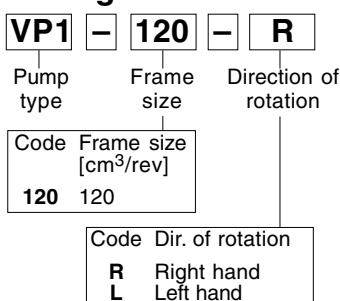

Standard model numbers

Model	Ordering no.
VP1-120-R	378 3182
VP1-120-L	378 3183

NOTE: - The direction of rotation cannot be changed. The desired direction of rotation must be stated when ordering
 - The suction fittings must be ordered separately (see information on page 7).

VP1-120 cross section

1. Control
2. Setting piston
3. Setting screw for LS control
4. Setting screw for pressure relief
5. Swash plate
6. Bearing shell
7. Purge plug
8. Drain for shaft seal
9. Needle bearing
10. Valve plate
11. Cylinder barrel
12. Barrel housing
13. Piston with piston shoe
14. Setting piston
15. Retainer plate
16. Bearing housing
17. Purge plug
18. Roller bearing
19. Shaft seals with carrier
20. Input shaft

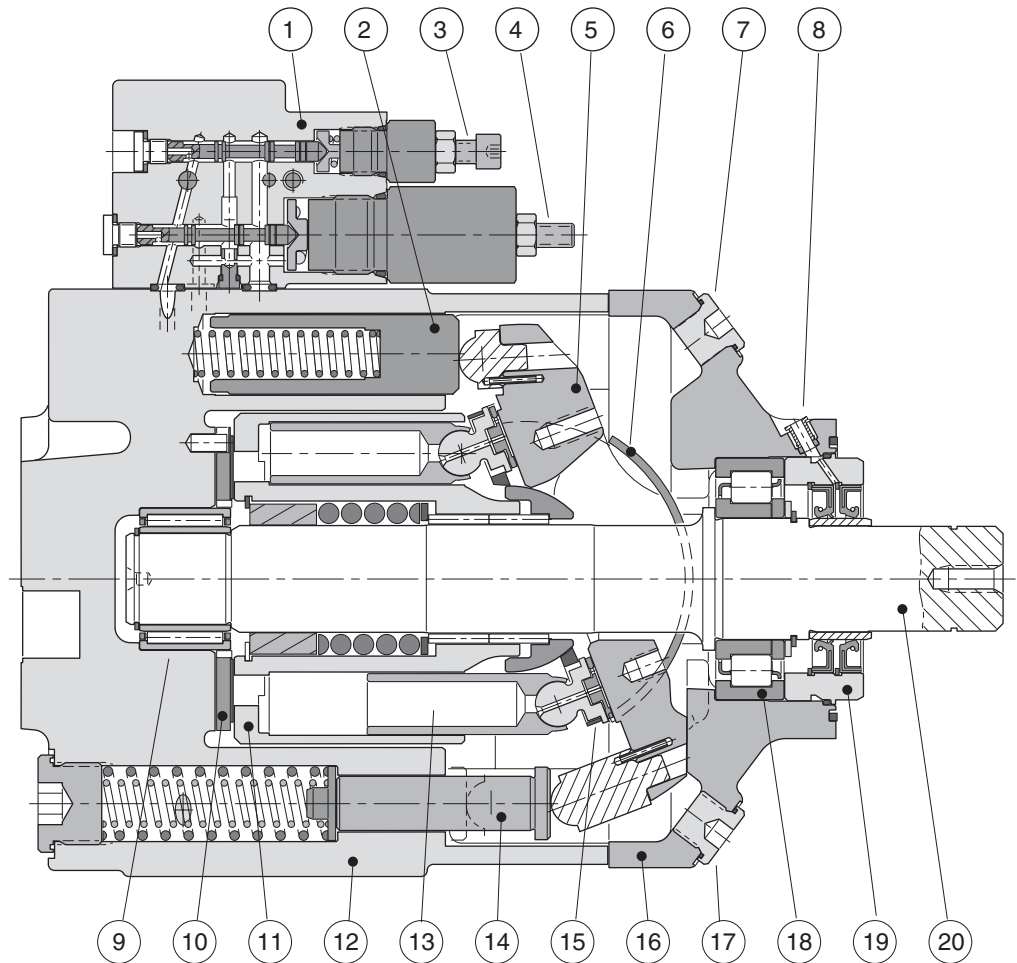

Control type LS (for VP1-120)

Load sensing port, high pressure (G 1/4")
 Direct connection to reservoir (G 3/8")

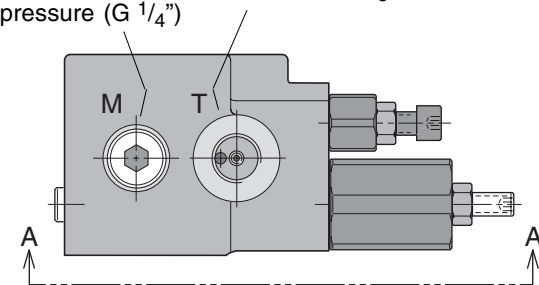

Port from high pressure
 Port to other setting pistons (No connection in pump housing)

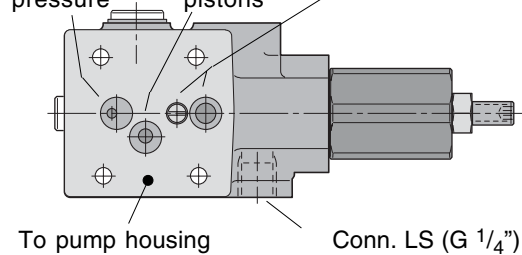

View A-A

Cross section of VP1-120 control.

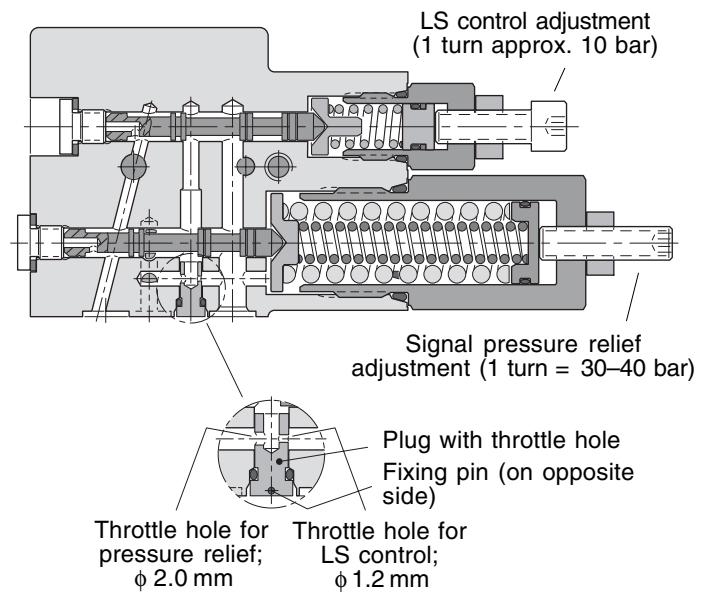

Note: See also the schematic on page 6.

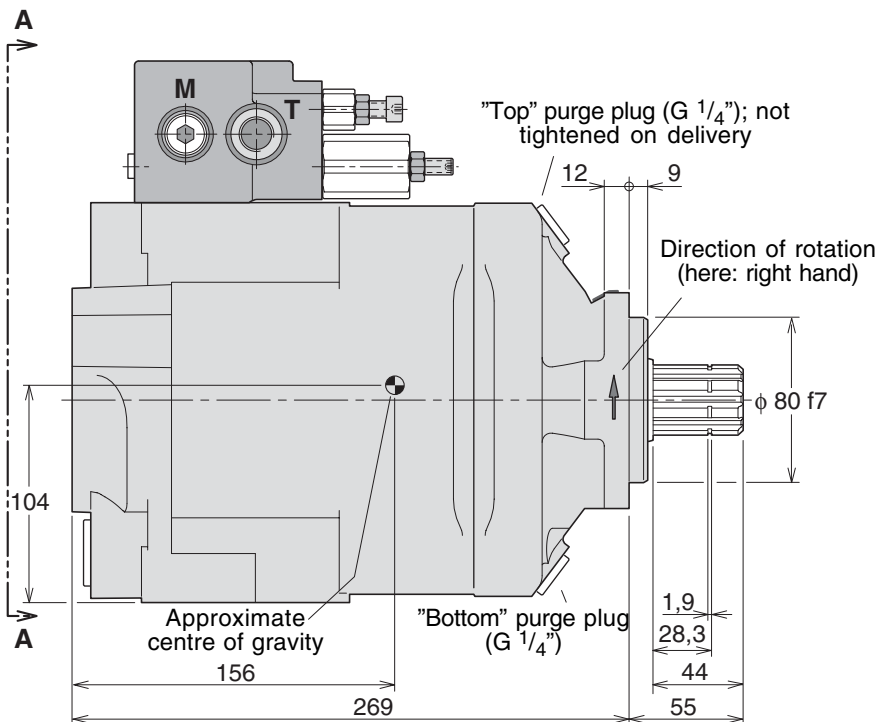
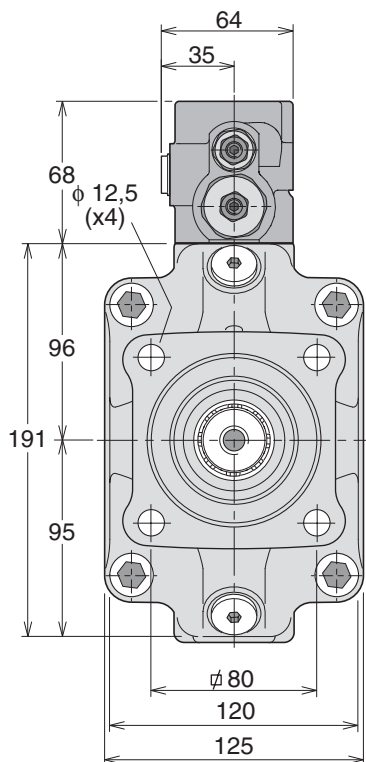

IMPORTANT!
 The control is *not* drained through the pump case. An external line must be installed between the control drain port 'T' and the reservoir.

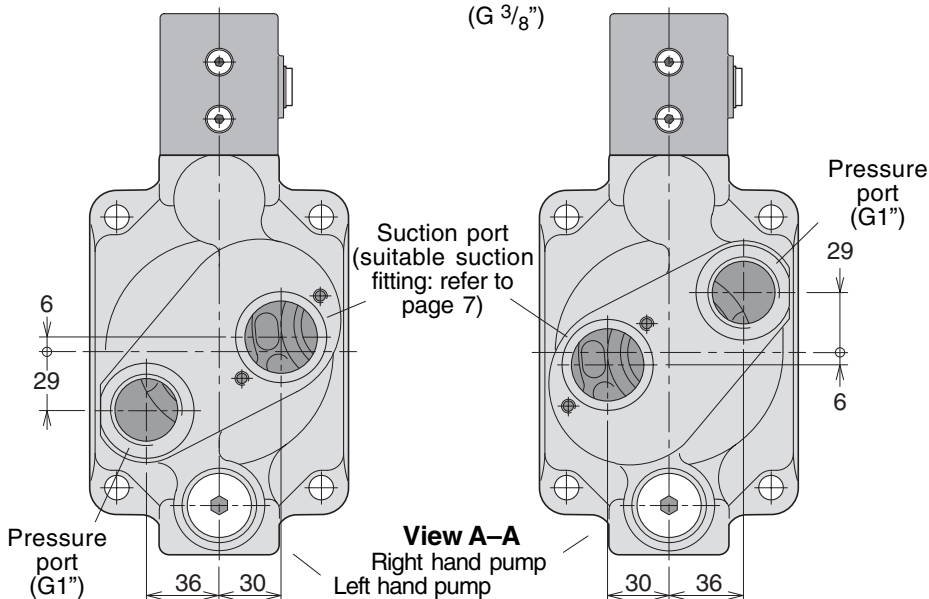
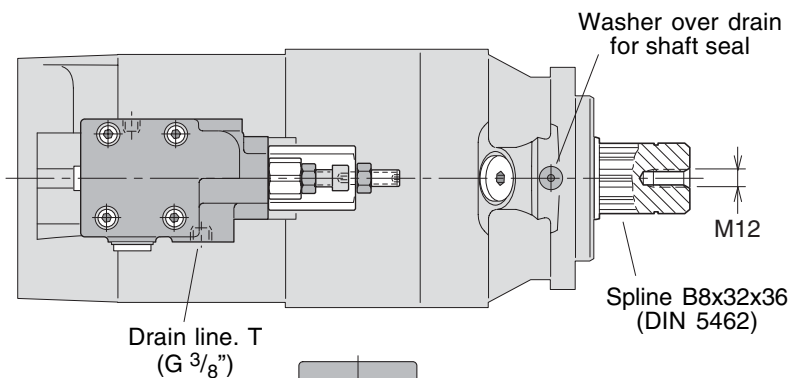

LS load sensing control (for VP1-120)

The VP1 pump can be used with any load sensing valve on the market. The control governs the pump flow to the hydraulic system as determined by the pressure differential, Δp , between the pump pressure and the signal pressure.

At a certain 'opening' of the directional valve, the pump flow is kept constant (up to max specified rpm and pressure limits of the pump) even if the pump pressure changes due to increasing or decreasing work load.

The LS control, consisting of a valve body, which is installed

on the main pump housing, determines the pressure levels for "standby pressure" (Δp) and "pressure relief". Both functions are adjustable.

As shown in the figure below, the control is connected to the system pressure, the LS signal and the setting piston.

When the pump does not need to deliver flow to any consumers (no-flow mode), the pressure in the signal line is zero. This means that the pump maintains the "standby" pressure as determined by the setting in the setting spring.

LS load sensing control function

Refer to the hydraulic schematic on the right.

A selected 'opening' of the directional control valve spool corresponds to a certain flow to the work function. This flow, in turn, creates a pressure differential Δp over the spool and, consequently, also a pressure differential between the pump outlet and the LS port.

When the differential pressure decreases (e.g. the directional valve is 'opened' further) the Δp also decreases and the LS valve spool moves to the left. The pressure to the setting pistons then decreases and the pump displacement increases.

The increase in pump displacement stops when the Δp finally reaches the setting and the forces acting on the valve spool are equal.

If there is no LS signal pressure (e.g. when the directional valve is in the neutral position) the pump only delivers sufficient flow to maintain the standby pressure as determined by the setting.

Control adjustments

- Signal pressure limiter
The valve is factory set at 275 bar but is adjustable to 350 bar.
- Standby pressure
 Δp is factory set at 25 bar but is adjustable to 35 bar.

The 25 bar setting and the standard orifice sizes shown (see also "Control type LS", page 4), will usually provide an acceptable directional valve characteristic as well as physical system stability.

For additional information, contact Parker Hannifin.

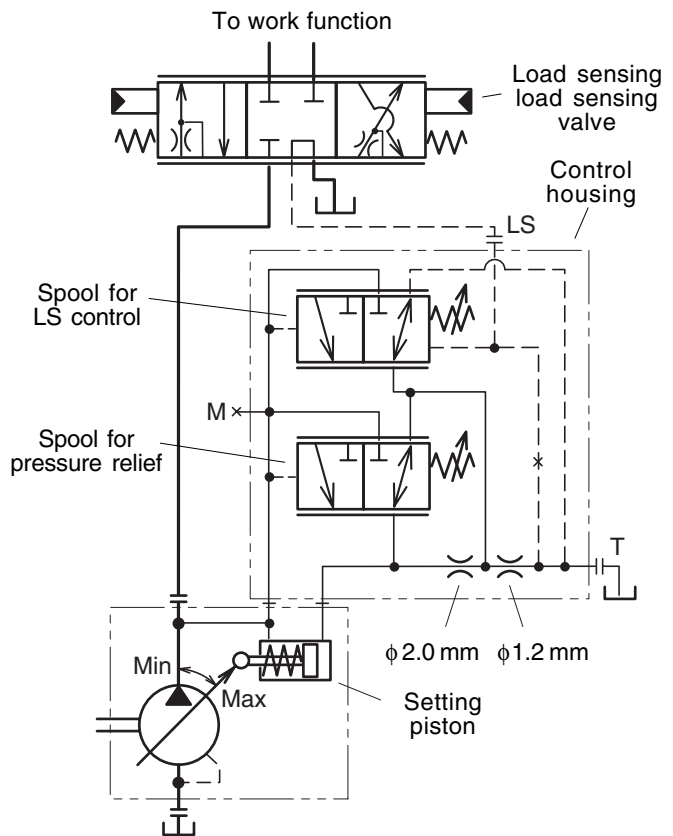

Hydraulic schematic for VP1-120.

BPV-VP1 unloading valve*

The BPV unloading valve for the VP1-120 is utilized in hydraulic systems where the pump is operating constantly. The valve, which requires no additional control valve, allows the pump to operate off-load for long periods, for example when fitted to a PTO.

The valve protects the pump from overheating in the off-load mode by allowing a small flow through the pump (refer to the schematic to the right). When a load sensing valve function is engaged, the bypass flow is cut off (as port 'X' is being pressurized).

Valve type	Ordering number	Rated flow [l/min]	Max press. [bar]
BPV-VP1	379 8799	20	350

* For more details, refer to the "Truck Hydraulics" catalogue, ordering number HY17-8200/UK, page 44.

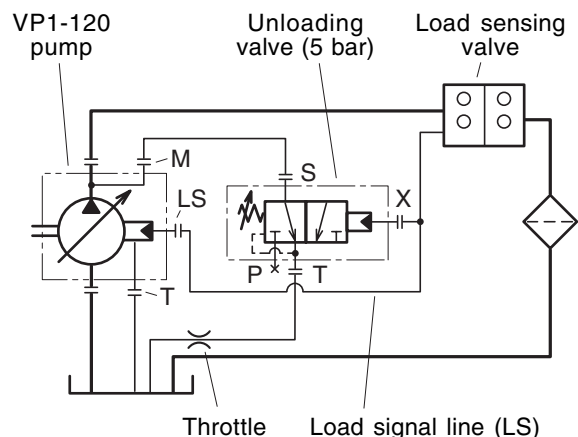

Suction fittings for VP1-120

A "suction fitting" consists of a straight, 45° or 90° fitting, 2 clamps, 2 cap screws and an O-ring.

NOTE: - Never use suction fittings smaller than the above.
- Suction fittings are not supplied with the pump, and must be ordered separately.

"Straight" suction fitting

Ordering no.	A mm	B mm	φ C mm (in.)
3780637	25	145	63 (2 1/2")

45° suction fitting

Ordering no.	A mm	B mm	φ C mm (in.)
3780634	75	117	63 (2 1/2")
3783367	88	129	75 (3")

90° suction fitting

Ordering no.	A mm	B mm	φ C mm (in.)
3781980	147	103	63 (2 1/2")

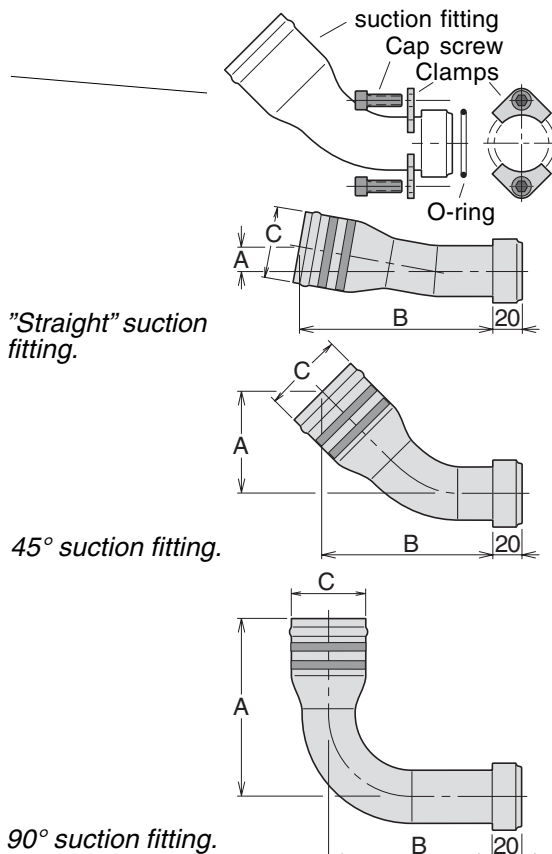

Start-up

Make sure the entire hydraulic system is clean before filling it with a recommended fluid.

In addition, the VP1 pump must be purged to remove any entrapped air in the pump housing; utilize the uppermost purge port (see figure).

Hydraulic fluids

The VP1 data shown in the specifications on page 3 are valid when operating on a high quality, mineral based fluid. Hydraulic fluids type HLP (DIN 51524), ATF (automatic transmission fluids), and API type CD engine oils are suitable.

Fluid temperature

Main circuit: Max 75 °C.

Viscosity

Recommended viscosity: 20 – 30 mm²/s (cSt).

Operating viscosity limits:

- Min 10 mm²/s; max 400 mm²/s.
- At start-up: max 1000 mm²/s.

Filtration

To obtain long VP1 life, we recommend a filtration level of:

- 25 μm (absolute) in clean environment or at low pressures
- 10 μm (absolute) in contaminated environment or at high pressures.

Filtration should meet ISO standard 4406, code 18/13.

Drain line

The LS-regulator requires a separate drain line, which must be routed directly to the reservoir (refer to the figure on the right).

IMPORTANT!

As shown in the figure, the pump inlet must always be below the lowest reservoir oil level.

Before starting, open the uppermost purge port and purge the pump. Afterwards, make sure both the ports are re-tightened.

Note! When the pump is purged the plug should be tightened with a torque of 30 Nm.

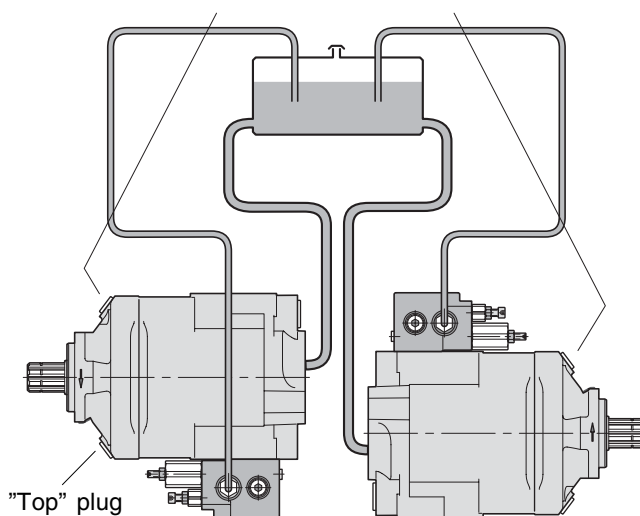

The VP1-120 pump should be installed below the reservoir fluid level. Purging should be performed when the pump is connected to the reservoir and the system is filled with fluid.

Hydraulics Group Sales Offices

Europe

Austria

Wiener Neustadt

Tel: +43 (0)2622 23501

Fax: +43 (0)2622 66212

Belgium

Nivelles

Tel: +32 (0)67 280 900

Fax: +32 (0)67 280 999

Czech Republic

Prague

Tel: +420 2 830 85 221

Fax: +420 2 830 85 360

Denmark

Ballerup

Tel: +45 4356 0400

Fax: +45 4373 8431

Finland

Vantaa

Tel: +358 (0)9 4767 31

Fax: +358 (0)9 4767 3200

France

Contamine-sur-Arve

Tel: +33 (0)450 25 80 25

Fax: +33 (0)450 03 67 37

Germany

Kaarst

Tel: +49 (0)2131 4016 0

Fax: +49 (0)2131 4016 9199

Hungary

Budapest

Tel: +36 (06)1 220 4155

Fax: +36 (06)1 422 1525

Ireland

Dublin

Tel: +353 (0)1 293 9999

Fax: +353 (0)1 293 9900

Italy

Corsico (MI)

Tel: +39 02 45 19 21

Fax: +39 02 4 47 93 40

The Netherlands

Oldenzaal

Tel: +31 (0)541 585000

Fax: +31 (0)541 585459

Norway

Ski

Tel: +47 64 91 10 00

Fax: +47 64 91 10 90

Poland

Warsaw

Tel: +48 (0)22 863 49 42

Fax: +48 (0)22 863 49 44

Portugal

Leca da Palmeira

Tel: +351 22 9997 360

Fax: +351 22 9961 527

Slovakia

Ref. Czech Republic

Spain

Madrid

Tel: +34 91 675 73 00

Fax: +34 91 675 77 11

Sweden

Spånga

Tel: +46 (0)8 597 950 00

Fax: +46 (0)8 597 951 10

United Kingdom

Warwick

Tel: +44 (0)1926 317 878

Fax: +44 (0)1926 317 855

International

Australia

Castle Hill

Tel: +61 (0)2-9634 7777

Fax: +61 (0)2-9899 6184

Canada

Milton, Ontario

Tel: +1 905-693-3000

Fax: +1 905-876-0788

China

Beijing

Tel: +86 10 6561 0520

Fax: +86 10 6561 0526

Asia Pacific Group

Hong Kong, Kowloon

Tel: +852 2428 8008

Fax: +852 2425 6896

India

Mumbai

Tel: +91 22 7907081

Fax: +91 22 7907080

Japan

Tokyo

Tel: +(81) 3 6408 3900

Fax: +(81) 3 5449 7201

Latin America Group

Brazil

Tel: +55 12 3954-5100

Fax: +55 12 3954-5266

South Africa

Kempton Park

Tel: +27 (0)11-961 0700

Fax: +27 (0)11-392 7213

USA

Cleveland (industrial)

Tel: +1 216-896-3000

Fax: +1 216-896-4031

Lincolnshire (mobile)

Tel: +1 847-821-1500

Fax: +1 847-821-7600

Parker Hannifin is the world's premier supplier of motion and control systems and solutions, with sales and manufacturing facilities throughout the world. For product information and details of your nearest Parker sales office, visit us at www.parker.com/euro_mcd or call free on 00800 2727 5374.



Catalogue HY17-8221/UK
3M 11/03 RT

© Copyright 2003
Parker Hannifin Corporation
All rights reserved.